

(Patent Pending)

Eye-D Cam

WPH-S WEATHERPROOF HOUSING & SUNSHIELD FOR THE A100 & A200 Eye-D Cam

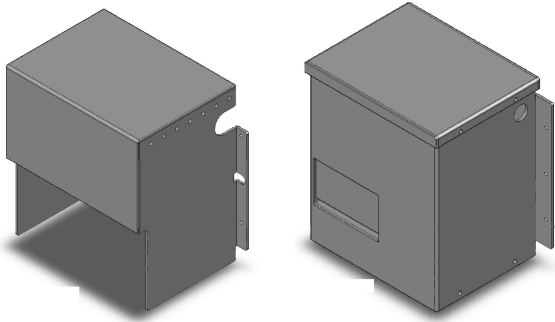

This Weatherproof housing and sunshield is suitable for mounting the A100-3 or A200-3 in an outside environment.

The housing is not dustproof, chemical proof, or explosion proof; however it is designed to allow these units to be mounted outdoors in a vertical position.

An internal heater and thermostat will allow the unit to operate in temperatures to zero degrees Fahrenheit.

The sunshield is designed to keep direct sunlight from overheating the unit. It will also reduce the effects of winter rain or snow.

WHAT YOU GET:

1. Environmental housing.
 - a. The housing will be mounted onto a flat surface that is at least 12" square.
 - b. The housing can be mounted independently of the sunshield with two screws or bolts. This will make it easier for the installer to install the unit.
 - c. A 1" dia. hole is provided to allow the technician to easily connect conduit for low voltage power and video transmission cables.
 - d. A space 11" H x 3-3/4" W x 7" D is provided for video transmission and other installer provided equipment.
 - e. The top is easily removable for installer access for cable connections.
 - f. Thermostat and heater are provided for warming during cold weather.
 - g. Access door allows visitors to insert their ID cards easily.
 - h. False floor prevents dropped cards from falling out of reach of the visitor.

2. Sunshield

- a. Used to protect the unit against direct summer sun.
- b. Holes near the top provide for convection cooling.

ADVANTAGES

- Provides outdoor ID card transmission to a central monitoring facility.
- Allows for video transmission equipment to be mounted in the same environmental enclosure.
- Makes it easy for a visitor to present their ID card for video identification.
- Made of a tough sun resistant plastic material.
- Designed with the installer and the user in mind.

SPECIFICATIONS:

MODEL	WPH-S
PHYSICAL	RUGGED (SUN RESISTANT) Plastic
Height	11-5/16" (287mm)
Width	11-5/8" (295mm)
Depth	7-11/16" (195mm)
Color	Black
Net Weight	34 oz (With A200-3 installed.)
Shipping Wt.	42 oz (With A200-3 installed.)
Wall mounting	6- 3/16" holes (Fasteners are not provided.)
Conduit access	1- One inch hole provided on right side

To order the Eye-D Cam or for more information:

email: jkoci@eyedcam.com

Phone: (888) 820-8318

Fax: (765) 807-5498

Mail: 5226 East 50 North
Lafayette, IN 47905

www.eyedcam.com

(888) 820-8318

Access & Video Integration Corporation